

City of Stillwater
Residential (1- & 2- Family) Permit Application Checklist
For New Houses and Additions

A Residential (1- & 2- Family) Permit application must be accompanied with all items indicated as **SUCH** are required for the submittal to be considered complete.

APPLICANT	REQUIREMENTS	CITY
	RESIDENTIAL (1- & 2- FAMILY) BUILDING PERMIT APPLICATION	
	COMPLETED CHECKLIST	
	TEMPORARY UTILITY AGREEMENT	
	ACKNOWLEDGEMENT OF STORMWATER REQUIREMENTS (2 PAGES)	
	ATTIC VENTILATION CALCULATION WORKSHEET	
	PURSUANT TO OKLA. STATE STATUTE TITLE 11, SECTION 43-109.2 : REQUIREMENT OF CONTRACTOR'S GENERAL LIABILITY INSURANCE (\$50,000 MINIMUM) AND WORKER'S COMPENSATION INSURANCE OR AFFIDAVIT OF EXEMPTION (FORM MAY BE ACQUIRED AT DEVELOPMENT SERVICES CENTER)	
	PER INTERNATIONAL RESIDENTIAL CODE, SECTION R106.1, TWO (2) SETS EACH OF THE FOLLOWING ARE REQUIRED WITH THE REQUIRED INFORMATION:	
	<ul style="list-style-type: none"> • A FOUNDATION PLAN, FROM THE APPROVED FOUNDATION TYPES FORM, WITH A CROSS SECTION OF THE PROPOSED FOUNDATION. THE PLAN SHOULD INCLUDE THE LOCATION OF ANY INTERIOR FOOTINGS REQUIRED TO SUPPORT INTERIOR BRACED WALL LINES OR LOAD-BEARING WALLS. • FLOOR PLANS FOR ALL FLOORS. THIS WOULD INCLUDE PROPOSED HABITABLE ATTICS. PLANS SHOULD BE DRAWN TO SCALE WITH APPROPRIATE DIMENSIONS INCLUDED. THE FLOOR PLANS SHOULD INCLUDE; <ul style="list-style-type: none"> • THE LOCATIONS AND METHOD OF EXTERIOR WALL BRACING IF OTHER THAN SOLID WOOD EXTERIOR SHEATHING. • THE LOCATION OF ANY REQUIRED INTERIOR BRACED WALLS. • THE LOCATION AND NOMINAL SIZE OF PROPOSED WINDOWS AND EXTERIOR DOORS. • IDENTIFICATION OF LOAD-BEARING WALLS OR COLUMNS. • IDENTIFICATION OF ANY LOAD-BEARING WALL SECTIONS INTENDED TO EXCEED 10-FEET IN HEIGHT BETWEEN PERPENDICULAR LATERAL SUPPORTS. • LOCATIONS OF ANY DECKS, PORCHES OR BALCONIES MORE THAN 30-INCHES HIGH AND ALL DECKS, PORCHES OR PATIOS THAT WILL BE COVERED BY A ROOF STRUCTURE. • IF PLANS INCLUDE WOOD-FRAME FLOORS, PROVIDE THE PROPOSED SIZE AND SPACING OF SAWN LUMBER FLOOR JOISTS, OR INDICATE THAT THE FLOOR WILL BE CONSTRUCTED WITH MANUFACTURED JOISTS OR TRUSSES. • ROOMS LABELED BY USE. • AT LEAST ONE ELEVATION PLAN INDICATING THE APPROXIMATE BUILDING HEIGHT. FOR MULTIPLE STORY BUILDINGS, INCLUDE THE PROPOSED ELEVATION DIFFERENCE BETWEEN FLOORS. <p>NOTE: PLANS MUST BE SUBMITTED ON PAPER AND MUST BE A SCALE AND OF A QUALITY TO BE LEGIBLE.</p>	
	R401.3.1 Finished Floor Elevation-Construction Located Within Floodplain Boundary: No construction shall commence on a structure located within the boundaries of a flood plain until an Earth Change Permit has been issued by the City. The finished floor elevation shall be established no less than one foot (1') above the base flood elevation (BFE) as indicated on the FEMA Elevation Certificate. A FEMA Elevation Certificate indicating initial floor elevations as set forth in said requirements shall be completed and submitted with the building permit application.	
	<p>FOR NEW CONSTRUCTION: TWO (2) PLANS</p> <p>SECTION R401.3.5 A RESIDENTIAL LOT GRADING AND DRAINAGE PLAN (RLP) SHALL BE SUBMITTED BY THE RESIDENTIAL BUILDING CONTRACTOR AND APPROVED BY THE CITY BEFORE A BUILDING PERMIT FOR ANY RESIDENTIAL STRUCTURE WILL BE ISSUED. THE RLP DRAWING SHALL BE PREPARED AT A SCALE OF 1"=20'. THE PLAN SHALL INCLUDE THE FOLLOWING:</p> <ul style="list-style-type: none"> • TITLE BLOCK IN LOWER RIGHT HAND CORNER WITH LOT OR PARCEL ADDRESS; • SUBDIVISION NAME, LOT AND BLOCK NUMBER, IF LOCATED WITHIN A PLATTED 	

	<p>SUBDIVISION;</p> <ul style="list-style-type: none"> • NAME, ADDRESS AND TELEPHONE NUMBER OF THE PROPERTY OWNER AND BUILDING CONTRACTOR; • DRAWING SCALE AND NORTH ARROW; • LOCATION OF STATUTORY AND ANY PLATTED BUILDING SETBACKS; • LOCATION OF PROPERTY BOUNDARIES INCLUDING ALL LOT DIMENSIONS; • FOOTPRINT(S) OF ALL STRUCTURES INDICATED BY SOLID LINE, INCLUDING DISTANCES TO THE PROPERTY LINES; • LOCATION OF ALL EASEMENTS LABELED BY TYPE AND WIDTH; • LOCATION OF THE EXISTING AND/OR PROPOSED PUBLIC SIDEWALK, CURB AND GUTTER; • LOCATION AND WIDTH OF DRIVEWAY, PRIVATE SIDEWALKS, DECKS, PORCHES, PATIOS; • PROPOSED DRAINAGE FLOW PATTERNS INDICATED BY FLOW ARROWS SHOWING PATH THAT SURFACE WATER WILL TAKE TO THE SITE BOUNDARIES OR POINTS OF DISCHARGE; • WHENEVER PROPERTIES ARE LOCATED WITHIN THE FLOODPLAIN, THE APPLICANT SHALL COMPLETE A FEMA ELEVATION CERTIFICATE. 	
	<p><u>FOR CONSTRUCTION OF AN ADDITION THAT EXCEEDS THREE HUNDRED (300) SQUARE FEET:</u> <u>TWO (2) PLANS</u> R401.3.6 RESIDENTIAL LOT GRADING AND DRAINAGE PLAN-EXISTING STRUCTURES. WHENEVER AN ADDITION TO AN EXISTING RESIDENTIAL STRUCTURE EXCEEDS THREE HUNDRED (300) SQUARE FEET IN AREA, A RESIDENTIAL LOT PLAN-EXISTING STRUCTURE (RLP-E) SHALL BE SUBMITTED BY THE BUILDING CONTRACTOR AND APPROVED BY THE CITY BEFORE A BUILDING PERMIT FOR SUCH ADDITION WILL BE ISSUED. THE REQUIREMENTS SET FORTH IN R401.3.1 THROUGH R401.3.4 SHALL APPLY TO ANY ADDITION TO AN EXISTING STRUCTURE UNLESS SPECIFICALLY EXCEPTED. THE FOLLOWING ADDITIONAL REQUIREMENTS SHALL APPLY:</p> <ul style="list-style-type: none"> • THE LOT SHALL BE GRADED LOCALLY AWAY FROM AND AROUND THE COMPLETED ADDITION. • DRAINAGE SHALL BE PROPERLY TRANSFERRED INTO THE EXISTING LOT SURFACE WATER DRAINAGE SYSTEM. • ANY AREA DIRECTLY IMPACTED BY THE ADDITION SHALL BE MODIFIED TO RESTORE EXISTING SURFACE WATER DRAINAGE. <p>THE RLP-E DRAWING SHALL BE PREPARED AT A SCALE OF 1"=20'. THE PLAN SHALL INCLUDE THE FOLLOWING:</p> <ul style="list-style-type: none"> • TITLE BLOCK IN LOWER RIGHT HAND CORNER WITH LOT OR PARCEL ADDRESS; • SUBDIVISION NAME, LOT AND BLOCK NUMBER, IF LOCATED WITHIN A PLATTED SUBDIVISION; • NAME, ADDRESS AND TELEPHONE NUMBER OF THE PROPERTY OWNER AND BUILDING CONTRACTOR; • DRAWING SCALE AND NORTH ARROW; • FOOTPRINT(S) OF ALL STRUCTURES INDICATED BY SOLID LINE, INCLUDING DISTANCES TO PROPERTY LINES; • LOCATION OF PROPERTY LINES; • RELATIVE FINISH FLOOR ELEVATION OF THE ADDITION IF IT IS DIFFERENT THAN THAT OF THE MAIN LEVEL OF THE EXISTING PRIMARY STRUCTURE. WHEN FLOOR ELEVATIONS ARE LOWER THAN THAT OF THE EXISTING STRUCTURE, THEN SECTION 401.3.7 SHALL APPLY WITH REGARD TO ADDITIONAL DOCUMENTATION; • LOCATION OF ALL EASEMENTS, LABELED BY TYPE AND WIDTH,; • LOCATION OF THE PUBLIC SIDEWALK, CURB AND GUTTER IF ALTERED BY THE ADDITION; • LOCATION AND WIDTH OF DRIVEWAY, PRIVATE SIDEWALKS, DECKS, PORCHES, PATIOS, IF IMPACTED BY THE ADDITION OR WHEN IT AFFECTS RESTORATION OF THE LOCAL DRAINAGE; • DIRECTION OF SURFACE WATER FLOW BY USE OF ARROWS SHOWING ANY NEW PATH(S) THAT SUCH WILL TAKE AROUND THE ADDITION, CONTINUING TO THE POINT OF DISCHARGE. THE TERMS "EXIST" OR (E) FOR EXISTING DRAINAGE PATH(S) OR "NEW" (N) FOR A NEW PATH(S) NEXT TO FLOW ARROWS SHALL BE USED TO DENOTE SUCH ON THE PLAN; • WHENEVER AN ADDITION OR UPGRADE TO AN EXISTING STRUCTURE IS LOCATED IN THE FLOODPLAIN, THE DESIGN OF SUCH ADDITION OR UPGRADE SHALL ALSO BE SUBMITTED TO THE STORMWATER PROGRAM MANAGER, WHO SHALL REVIEW SUCH PLANS AND IDENTIFY ANY ADDITIONAL FEMA REQUIREMENT(S). 	

R401.3.7 RESIDENTIAL LOCATION AND ELEVATION PLAN. A RESIDENTIAL LOCATION AND ELEVATION PLAN (RLEP) PREPARED BY AN OKLAHOMA LICENSED LAND SURVEYOR, SHALL BE SUBMITTED TO AND ACCEPTED BY THE CITY UPON COMPLETION OF THE FOUNDATION FORMS OR COMPLETION OF THE FOUNDATION AND SLAB, BEFORE PROCEEDING WITH FURTHER VERTICAL CONSTRUCTION ON A RESIDENCE OR A RESIDENTIAL ACCESSORY STRUCTURE GREATER THAN 300 SQUARE FEET. RLEPs ARE NOT REQUIRED FOR LOTS THAT ARE 20,000 SQUARE FEET OR GREAT IN SIZE AND THAT WILL HAVE BUILDING SETBACKS THAT WILL EXCEED ALL REQUIRED SETBACKS BY MORE THAN 10 FEET. THE RLEP DRAWING SHALL BE PREPARED AT A SCALE OF 1"=20'. THE PLAN SHALL INCLUDE THE FOLLOWING:

- TITLE BLOCK IN LOWER RIGHT HAND CORNER WITH LOT OR PARCEL ADDRESS;
- SUBDIVISION NAME, LOT AND BLOCK NUMBER, IF LOCATED WITHIN A PLATTED SUBDIVISION;
- NAME, ADDRESS AND TELEPHONE NUMBER OF THE PROPERTY OWNER AND BUILDING CONTRACTOR;
- DRAWING SCALE AND NORTH ARROW;
- FOOTPRINT(S) OF ALL STRUCTURES INDICATED BY SOLID LINES, INCLUDING DISTANCES TO PROPERTY LINES;
- PROPERTY LINES AND DIMENSIONS TO CORNERS OF STRUCTURE;
- LOCATION OF THE RELATIVE FINISHED FLOOR ELEVATION OF THE STRUCTURE;
- THE RELATIVE ELEVATION OF THE DISCHARGE POINTS;
- LOCATION OF ALL EASEMENTS, LABELED BY TYPE AND WIDTH;
- SURVEYOR'S SIGNATURE AND SEAL WITH DATE.

THE ACCEPTANCE OF THE RLEP BY THE CITY SHALL NOT RELIEVE THE RESIDENTIAL BUILDING CONTRACTOR AND/OR THE PROPERTY OWNER BUILDING HIS/HER OWN RESIDENCE OF ANY RESPONSIBILITY FOR COMPLIANCE WITH ALL APPLICABLE REGULATIONS AND SUCH ACCEPTANCE SHALL NOT WAIVE ANY REQUIREMENTS OF THIS CHAPTER OR OF THE ADOPTED IRC AND LOCAL AMENDMENTS THERETO.

Certification: I hereby certify that the information provided herein is both complete and accurate to the best of my knowledge and I understand that any inaccuracies may be considered just cause for invalidation of this application and any action taken on this application.

Preparer's Signature

Date



BP# _____

723 S. Lewis, P.O. Box 1449, Stillwater OK 74076

www.stillwater.org

Fax # 405-742-8321

RESIDENTIAL (1&2 Family) Permit Application

New Construction Alteration Addition Remodel Accessory Storm Shelter Modular Other

Project Address: _____

FOR OFFICE USE ONLY: FEMA floodplain? Yes No

Lot #: _____ Block # _____ Subdivision: _____ Zoning: _____

IF UNPLATTED PROVIDE COPY OF DEED

Property Owner: _____ Address: _____ Phone: _____

Contractor: _____ Address: _____

Phone Number: _____ Fax Number: _____

OWNER/CONTRACTOR SIGNATURE OF UNDERSTANDING AND AGREEMENT

I hereby certify that the statements in this application and the attachments hereto are accurate, that the property owner has given permission for this work to proceed, that all construction work under this permit will conform to all applicable ordinances, rules or regulations of the City of Stillwater, and that all electrical, plumbing, mechanical, fence, sign and driveway construction shall be performed by contractors licensed by the State of Oklahoma (if applicable) and registered and bonded with the City of Stillwater.

(OWNER)(CONTRACTOR): **SIGNED** _____ DATE _____

(OWNER)(CONTRACTOR): **PRINT** _____ DATE _____

DESCRIPTION:

Number of Stories: _____ # of Bedrooms: _____ # of Bathrooms: _____ # of Water Closets _____

Electric Service (# of amps): _____ Service Lateral Connection Fee: 200 AMPs=\$400.00 400 AMPs=\$700.00

(For service over 400 AMPs, contractor must contact Electric Utility to obtain connection fee.) Effective 01.01.2011 per Resolution CC-2010-18; SUA-2010-10

Water Meter: 3/4" 1" Work Order# _____

Sewer Service: Public Septic (if Septic, provide copy of Perk Test)

Other _____

Exterior Wall Finish: _____ Roof Covering: _____

Square Footage

Finished: 1st _____ 2nd _____ Unfinished: 1st _____ 2nd _____ Garage: _____

Total Sq. Ft.: _____ Lot Square Footage: _____ % Lot Coverage: _____

Valuation: \$ _____ (Valuation includes structural, electrical, plumbing, mechanical, interior finish, overhead and profit R108.3.)

(All contractors MUST be licensed and registered with the City of Stillwater and the State of Oklahoma)

Plumbing Contractor: _____ Contact: _____ Phone: _____

Mechanical Contractor: _____ Contact: _____ Phone: _____

Electrical Contractor: _____ Contact: _____ Phone: _____

Driveway/Sidewalk Contractor: _____ Contact: _____ Phone: _____

The granting of a permit or approval of plans shall not be construed as permission to violate any federal, state or local laws. Special notice is hereby given that additional requirements, notices and regulations will be printed on the permit and plans and shall be complied with whether specified herein or not.

Special notice is also hereby given that this permit becomes null and void if the authorized work or construction is not commenced, is suspended or abandoned after work is commenced, or if no inspections are obtained within a 6 month period. This permit requires final inspections and a Certificate of Occupancy or Certificate of Completion.

Revised 07.01.2017



TEMPORARY UTILITES AGREEMENT

Pursuant to City of Stillwater Terms and Conditions of Use temporary power and water service for construction purposes may be activated upon issuance of a building permit and the temporary equipment and services having been inspected and approved and upon signing of this document.

The City frequently receives requests to activate gas, water, and electric services before the building has been completed. This may be granted when the City confirms that particular utilities work is complete and safe to operate under construction conditions. Temporary service equipment will be disconnected when the permanent equipment to the building is activated, with the possible exception of equipment serving remote job site trailers or offices.

I, the undersigned and building permit applicant, agree and understand that temporary utility services are being allowed only for the purpose of construction and I will call for final inspections and obtain a certificate of occupancy or a temporary certificate of occupancy, before the building or addition to the existing building is occupied or used for any other reason (including storage of items other than building materials and tools).

I, the undersigned and building permit applicant, understand that temporary utility services may be disconnected at anytime the property is found to be in violation of the Terms and Conditions of Use.

I, the undersigned and building permit applicant, agree the furnace is NOT to be operated any time fumes are present (such as glue, paint, dust, etc.), or any other substance harmful to the furnace. No electrical equipment may be left in an unsafe condition. It is not in the best interest of the building's owner to operate permanent HVAC system for temporary heating or cooling purposes during construction.

I, the undersigned, do agree to assume all responsibility for any cost associated with these temporary utilities. I, the undersigned, do understand that once a Certificate of Occupancy or Certificate of Completion is issued or upon completion of the construction project outside the city limits, then City of Stillwater Customer Service shall be contacted to change the status of the utility account.

I understand and agree that temporary water service is for construction purposes only and is NOT to be connected to any building/structure in any manner, whether directly or indirectly, until a permitted sewer connection is made to an approved sewage disposal system. I also understand that prior to issuance of a certificate of occupancy, any costs associated with the relocation/adjustment of the meter can or repairs required on the City's side of the meter due to damages during construction will be my responsibility.

I understand that a violation of any of the above conditions, or failure to comply with the requirements of and within the time constraints of the Terms and Conditions of Use, shall be considered a Class A Offense and may result in the immediate disconnection of the utility services and/or issuance of a municipal citation.

Project Address _____

Print Name _____

Signature _____ Date _____

Billing Address _____

Phone Number: _____

Attic Ventilation Calculation Worksheet

Address: _____

Contractor: _____

Type and Amount of roof ventilation proposed: **(check ALL that apply)**

	Size	Length	# of	Manufacture
<input type="checkbox"/> Soffit Vent				
<input type="checkbox"/> Gable End Vents				
<input type="checkbox"/> Ridge Vent				
<input type="checkbox"/> Hood Roof Vents				
<input type="checkbox"/> Turbine Vents				

Total NFVA Area Proposed = _____

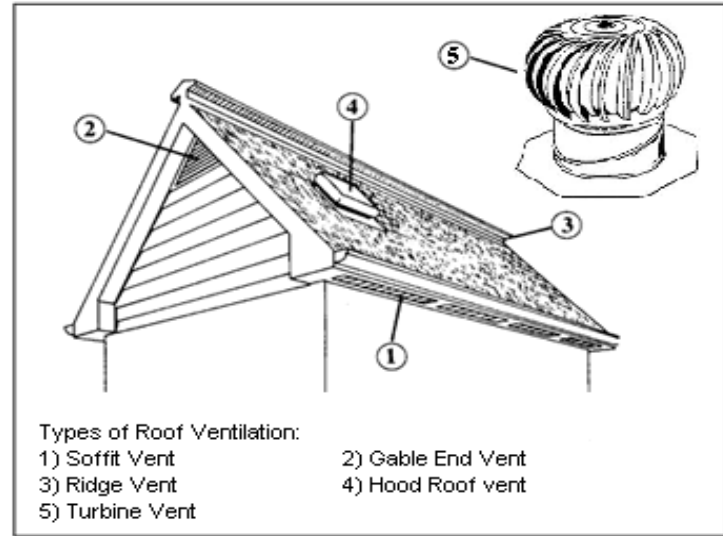

Ventilation Calculation

A. Attic area square footage	=		Square Feet
B. Attic area (divided by) 150 <u>or</u> 300	=		Sq Ft of attic ventilation required
C. Sq Ft of attic ventilation required x 144	=		Sq inches of Net Free Ventilation Area required*
Total NFVA Area Required =			

NFVA - Note: *The net-free area can be as much as 50% less than the gross opening area. The manufacturer's literature should be consulted to obtain free-area information.*

***(IRC), IBC Minimum area.** The total net free ventilating area shall not be less than 1 to 150 of the area of the space ventilated except that the total area is permitted to be reduced to 1 to 300, provided at least 50 percent (and not more than 80 percent) of the required ventilating area is provided by ventilators located in the upper portion of the space to be ventilated at least 3 feet (914 mm) above eave or cornice vents with the balance of the required ventilation provided by eave or cornice vents.



Department of Development Services 723 S. Lewis Street Stillwater, Oklahoma 74074
 Office: (405) 742-8218 Fax: (405) 742-8321 Web: stillwater.org
 Form Date: 07.01.2015

Attic Spray Foam Worksheet

Address: _____

Contractor: _____

Type of spray foam proposed: (check ALL that apply and provide product spec sheets)

If product information is not known, enter "Will submit later"

	<u>Product Name</u>	<u>Manufacturer</u>
<input type="checkbox"/> Open Cell	_____	_____
<input type="checkbox"/> Closed cell	_____	_____
<input type="checkbox"/> Ignition barrier	_____	_____
<input type="checkbox"/> Approved without additional ignition barrier		

Attic storage information

<input type="checkbox"/>	Attic storage is planned
<input type="checkbox"/>	No attic storage is planned
<input type="checkbox"/>	Attic storage is planned but will be separated from insulated attic

R316.5.3 Attics. The thermal barrier specified in Section R316.4 is not required where all of the following apply:

1. Attic access is required by Section R807.1.
2. The space is entered only for purposes of repairs or maintenance.
3. The foam plastic insulation is protected against ignition using one of the following ignition barrier materials:
 - 3.1. 1 1/2-inch-thick (38 mm) mineral fiber insulation;
 - 3.2. 1/4-inch-thick (6.4 mm) wood structural panels;
 - 3.3. 3/8-inch (9.5 mm) particleboard;
 - 3.4. 1/4-inch (6.4 mm) hardboard;
 - 3.5. 3/8-inch (9.5 mm) gypsum board; or
 - 3.6. Corrosion-resistant steel having a base metal thickness of 0.016 inch (0.406 mm).

The above ignition barrier is not required where the foam plastic insulation has been tested in accordance with Section R316.6.



Department of Development Services 723 S. Lewis Street Stillwater, Oklahoma 74074

Office: (405) 742-8218 Fax: (405) 742-8321 Web: stillwater.org

Form Revised: 07.01.2017

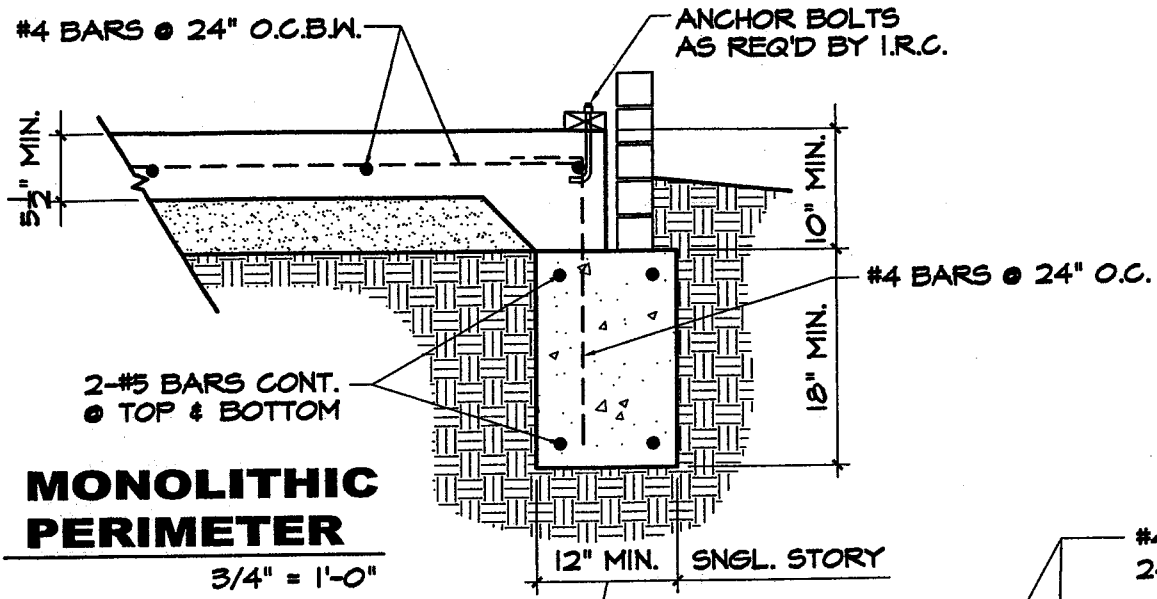

MONOLITHIC PERIMETER

3/4" = 1'-0"

SEE TABLE 403.1
IN 2009 IRC FOR
OTHER THAN
SINGLE STORY.

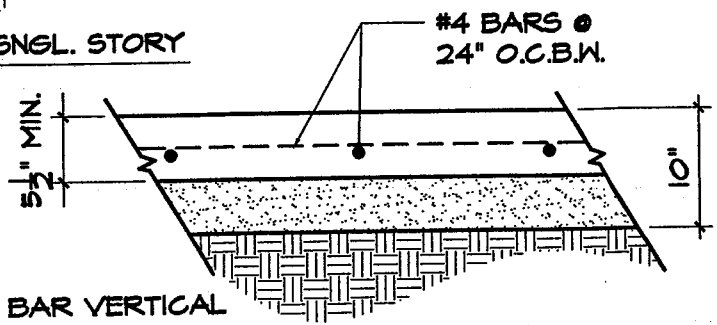

LOAD BEARING INTERIOR

FOR 2-STORY
STRUCTURES ONLY
3/4" = 1'-0"

NOTES:

1. BOTTOMS OF ALL BEAMS SHALL EXTEND TO UNDISTURBED SOIL OR COMPACTED SOIL.
2. JOINT OVERLAP OF BAR STEEL TO BE NOT LESS THAN 40 BAR DIAMETERS.
3. MINIMUM COVER ON STEEL IN SLAB SHALL BE 2 1/2".
4. MINIMUM COVER ON STEEL IN FOOTING SHALL BE 3" CLEAR FROM BOT. OF FOOTING & 3" CLEAR FROM SIDE WALLS.
5. FOOTING STEEL SHALL BE TIED & SUPPORTED EVERY 5'-0" MAX.

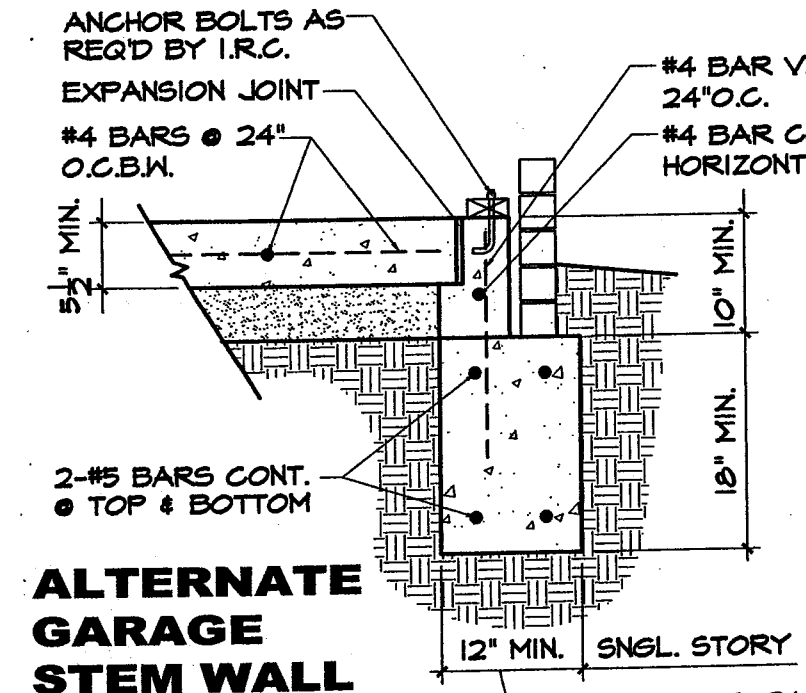

ALTERNATE GARAGE STEM WALL PERIMETER

3/4" = 1'-0"

SEE TABLE 403.1
IN 2009 IRC FOR
OTHER THAN
SINGLE STORY.

ALTERNATE DESIGN FOR FOUNDATION & FLOOR

FOR SOIL WITH P.I. OF 30 OR MORE
REFEFENCE PAYNE COUNTY SOIL MAP AS PUBLISHED BY
USDA SOIL CONSERVATION SERVICE

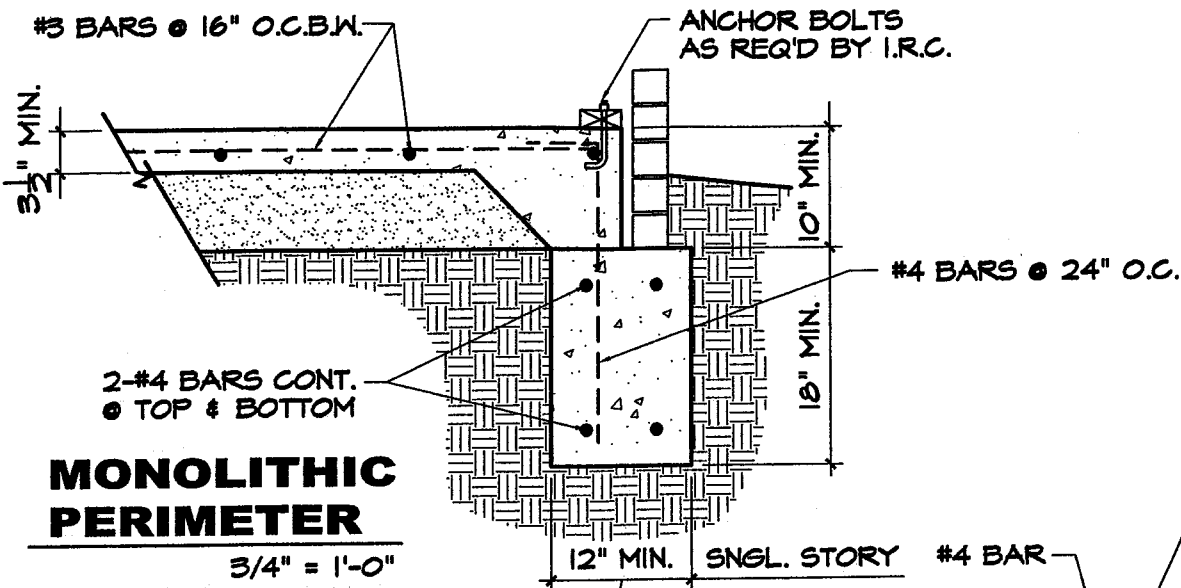

MONOLITHIC PERIMETER

3/4" = 1'-0"

SEE TABLE 403.1
IN 2009 IRC FOR
OTHER THAN
SINGLE STORY.

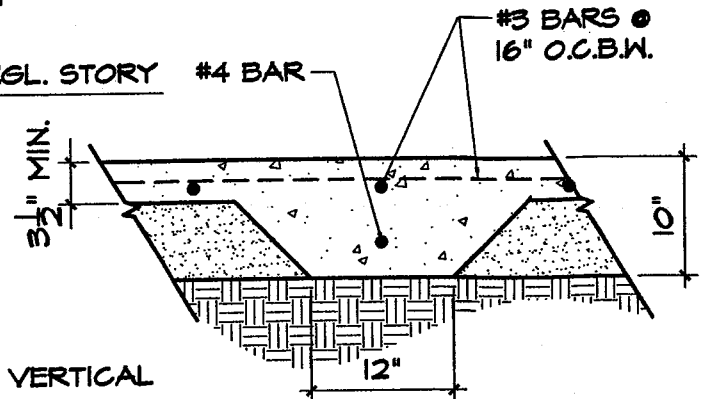

LOAD BEARING INTERIOR

FOR 2-STORY
STRUCTURES ONLY 3/4" = 1'-0"

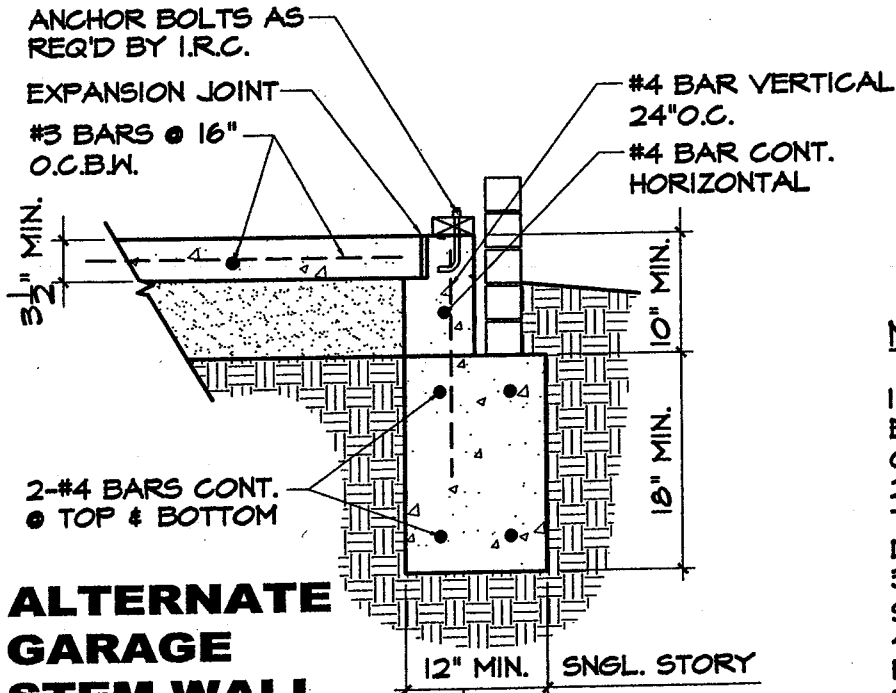

ALTERNATE GARAGE STEM WALL PERIMETER

3/4" = 1'-0"

SEE TABLE 403.1
IN 2009 IRC FOR
OTHER THAN
SINGLE STORY.

NOTES:

1. BOTTOMS OF ALL BEAMS SHALL EXTEND TO UNDISTURBED SOIL OR COMPACTED SOIL.
2. JOINT OVERLAP OF BAR STEEL TO BE NOT LESS THAN 40 BAR DIAMETERS.
3. MINIMUM COVER ON STEEL IN SLAB SHALL BE 1 1/2".
4. MINIMUM COVER ON STEEL IN FOOTING SHALL BE 3" CLEAR FROM BOT. OF FOOTING & 3" CLEAR FROM SIDE WALLS.
5. FOOTING STEEL SHALL BE TIED & SUPPORTED EVERY 5'-0" MAX.

ALTERNATE DESIGN FOR FOUNDATION & FLOOR

FOR SOIL WITH P.I. OF 29 OR LESS
REFEFENCE PAYNE COUNTY SOIL MAP AS PUBLISHED BY
USDA SOIL CONSERVATION SERVICE



Project: _____

Building Permit No.: _____

Acknowledgement of Stormwater Requirements

Drainage Facilities

Proper stormwater management is essential to public welfare.

For construction scheduling purposes, municipal code §9-32 (a) states: *All drainage facilities shown as part of an accepted drainage plan for any portion of a development shall be installed as part of the first phase of construction or earth moving activity on that portion of the development.*

For all phases of construction, §9-7 (a-b) states:

(a) Dumping or placing any material, whether temporary or permanent, within a drainage facility in a drainage easement or within the stormwater flowline of a drainage facility that is not in an easement is prohibited and a violation of this article. The owner of the property shall be responsible for any material that has been willfully dumped or placed in a drainage facility.

(b) A property owner's failure to repair and maintain a drainage facility that was specifically designed and installed to control stormwater runoff from that property or other properties designated in an approved drainage plan to a standard allowing it to perform its designed and intended purpose is prohibited and a violation of this article.

Municipal Code §9-21 (a) (2) states: *All development, redevelopment, and earth changes shall be constructed so that it will not increase the frequency of flooding or depth of flood for any stream, up to and including the 24 hour – 100 year storm.*

Water Quality Regulations

The City of Stillwater is an Oklahoma Department of Environmental Quality Phase II community and is required by federal and state regulations to enforce a program that effectively reduces stormwater runoff pollution resulting from construction activities.

Municipal Code, §9-21 (b) (1-3) states:

(1) All development, redevelopment, and earth changes shall be designed, constructed, and completed in a manner which minimizes the exposure of bare earth to precipitation.

(2) All development, redevelopment, and earth changes shall be constructed only if appropriate sedimentation facilities are installed and maintained throughout the construction period.

(3) All development, redevelopment, and earth changes shall be accompanied by Best management practices for controlling sediment and erosion so as to minimize the amount of sediment leaving the site.

Municipal Code, §9-40 states: *Unless specifically exempted, an earth change permit [now identified as the Earth Change, Grading, and Flood Control Permit] granted to the provisions of this chapter shall be obtained from the city engineer prior to commencement of any excavating, grading, re-grading, landfilling, berming, or diking of any property within the jurisdictional area of the City of Stillwater. A separate permit shall be required for each separate, noncontiguous site or lot. No permit shall be transferable without the prior written consent of the city engineer.*

Floodplain Regulations

If construction is to take place within an identified Special Flood Hazard Area (SFHA), that proposed development must be constructed to comply with floodplain management regulations and to minimize potential flood risks. Chapter 23 – Article 14, *Flood Hazard Regulations*, requires:

1. For residential structures, the lowest floor (including basements) must be elevated above the base flood elevation (BFE) a minimum of one foot (1'-0").
2. For non-residential structures, the lowest floor or base of the structure must be elevated above the base flood elevation (BFE) a minimum of one foot (1'-0") - OR - shall be flood proofed to withstand the flood depths, pressures, velocities, and impact and uplift forces associated with the 100-year (1% chance) flood.
3. For all structures, the foundation and materials used must be constructed in such a manner as to withstand the pressures, velocities, and impact and uplift forces associated with the 100-year (1% chance) flood.
4. All new construction, substantial improvements, or other development shall be constructed with materials resistant to flood damage and by methods and practices that minimize flood damage.
5. All new construction, substantial improvements, or other development shall be accomplished without causing adverse impact to other properties. Compensatory storage shall be provided for any fill or obstruction located within the floodplain that reduces or modifies floodplain characteristics and parameters as determined by FEMA regulatory mapping.
6. You must submit an official FEMA Elevation Certificate from an Oklahoma-registered engineer, architect, or land surveyor which indicates that the base floor elevation requirements have been met. You must submit written certification from an Oklahoma registered engineer or architect that the flood proofing requirements have been met when flood proofing has been used as an alternative for non-residential structures. Failure to provide required certification is a violation of this permit and will result in withholding the Certificate of Occupancy or Certification of Completion.
7. All utility supply lines, outlets, switches, and mechanical or electrical equipment must be installed so as to minimize damage from potential flooding, either by elevating the equipment a minimum of one foot (1'-0") above the base flood elevation (BFE) or by flood proofing the systems. Water and sewer connections must have back-flow preventer devices installed.

Violations and Enforcement

Violations of stormwater requirements will result in the issuance of a Notice of Noncompliance (NON). Violations must be corrected within the noted correction period. If a violation is not corrected within the correction period, a citation will be issued every day, thereafter, until the violation is corrected. The violation is a class C offense (\$500/day) if no sediment is discharged; it is a Class D offense (\$1,000/day and/or 90 days in jail) if sediment is discharged.

Earth Change, Grading, and Flood Control Permit Holders will receive a maximum of (5) citations (1 per day per violation). The permit will be revoked or suspended on the 6th day. If revoked or suspended, a Stop Work Order will be issued. For violations which create a public nuisance, abatement actions may be taken by the City of Stillwater and related expenses will be billed to the property owner.

Authorization and Acknowledgement

I have read or had read to me the above stormwater provisions; I understand and will abide by these requirements.

Owner's Name (*please print*)

Signature of Owner

Date



Department of Operations
Water Utilities Service Center
707 E 8th Ave
Stillwater, OK 74075

Office: 405.533-8048
Fax: 405.533-8044
Web: Stillwater.org

PLEASE PROVIDE INFORMATION NEEDED TO FACILITATE ALL NEW WATER METER REQUESTS

Contact Name: _____

Office phone #: _____

Cell phone #: _____

Meter set address: _____

1. Date the meter requested to be set by: _____
2. Water distribution crew needs a wood stake placed to:
 - a. Show location where customer prefers the meter box to be set.
 - b. Mark the finished grade on the stake.
3. After stake has been set, kindly contact the Water Distribution Service Center:
 - a. Administrative Assistant **Staci Cundiff** at (405) 533-8048 – scundiff@stillwater.org or
 - b. Water Distribution Deputy Team Leader **Kelley Hitch** at (405) 880-7037 khitch@stillwater.org
4. Until the Water distribution staff is contacted with staking information, the meter request will be put on hold.
5. Please be informed that:
 - a. We install water meter taps and meter set in the order received by water distribution.
 - b. Meter sets that require road crossing will need a road bore. The road bore has to be scheduled with a boring contractor. For county road bores a road crossing permit is required, and the application is submitted to the county.

Should you have any questions, please do not hesitate to call.

Thank you

OFFICE USE ONLY:

Copy given to customer

Work order number: _____

Completed by: _____